

## Hydraulic Systems

As hydraulic driven equipment becomes more sophisticated, the need increases for a better understanding of its operation and maintenance. Hydraulic systems can be either simple or complex. They can operate at high temperatures (e.g. 60°C, 140°F), pressures and rapid cycle times. We will divide the broad subject matter of hydraulics into smaller topics and cover each in separate bulletins. This will provide you with a better understanding of each subject. This opening bulletin will give you some basic understanding of hydraulics. Future subjects to be covered will include sources of contamination, filter performance indicators, hydraulic fluid additives, recycling and preventive maintenance.

To begin, the basic law of hydraulics is stated by Pascal, "pressure at any point in a static liquid is the same in every direction and exerts an equal force on all equal areas." (See Figure 1) Fluids are virtually incompressible, mechanical forces may be directed and controlled by means of fluids under pressure.

**FIGURE 1**

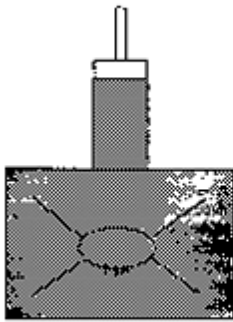

Pascal's Law: Pressure at any one point in a static liquid is the same in every direction and exerts equal force on equal areas.

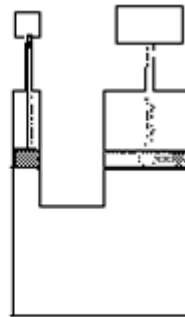

Mechanical forces can be transmitted, multiplied, and controlled by hydraulic fluid under pressure because force equals pressure times area.

Most hydraulic circuits contain five basic mechanical components: a reservoir, a pump, a filter, a pump, flow control valves, and a cylinder or actuator (see Figure 2).

## Hydraulic Systems

There is also the hydraulic fluid to consider. No matter how sophisticated the system gets, the hydraulic fluid in the system performs four simple functions:

1. Transmit power
2. Lubricate the pump, valves and seal
3. Protect the system by removing contaminants
  - Moisture
  - Dirt
  - Heat
  - Air
4. Sealing internal components

**FIGURE 2**

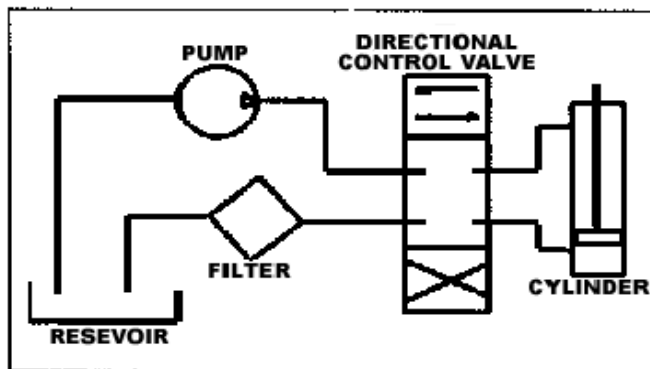

The pressure applied to the fluid will give the fluid the power necessary to transmit a force within the system. As the sophistication of the system increases, the work required of the fluid will also increase. The fluid transmits power while it lubricates the components which it flows through. The hydraulic fluid, as a lubricant, reduces friction in the components by producing a barrier or film which separates the surfaces that will roll or slide past each other.

Viscosity is a measure of a fluid's resistance to flow. A fluid that has a high resistance to flow (high viscosity) is like cold molasses or SAE 140 weight gear oil. A fluid that has a low resistance to flow (low viscosity) is like water or SAE 10 weight hydraulic oil. Viscosity of the fluid is directly related to its ability to lubricate. A high viscosity fluid generates greater film thickness between lubricated surfaces because it has a greater resistance to being squeezed out from between the lubricated surfaces (viscosity requirements are system specific; refer to your manufacturers recommendations for your particular application). Viscosity of the fluid will change with the temperature of the fluid. Raising the

# Hydraulic Systems

temperature of the fluid will decrease its viscosity. Conversely, lowering of the temperature will increase its viscosity.

In many instances, the fluid is the only seal against pressure inside a hydraulic component where no seal ring exists between the valve spool and body to minimize leakage from high to low pressure areas. The close mechanical fit and oil viscosity determines leakage rate.

To keep friction and wear of the system to a minimum, the proper filtration must be specified and you must use a fluid of the correct viscosity while operating the system within the proper design parameters.

For further information about hydraulics refer to the latest FMC Technical Service Bulletins 96-2, 96-3, and 97-1, as well as the NFPA (National Fluid Power Association) Publications Catalog.

### FOR ADDITIONAL INFORMATION, CONTACT:

Filter Manufacturers Community ■ 7101 Wisconsin Ave., Suite 1300 ■ Bethesda, MD 20814

P 301-654-6664 ■ F 301-654-3299 ■ W [autocare.org/fmc](http://autocare.org/fmc) ■ FMC is a community of the Auto Care Association